



# ENCORE LPI2Z IP



**User Manual**

©2023 ADJ Products, LLC all rights reserved. Information, specifications, diagrams, images, and instructions herein are subject to change without notice. ADJ Products, LLC logo and identifying product names and numbers herein are trademarks of ADJ Products, LLC. Copyright protection claimed includes all forms and matters of copyrightable materials and information now allowed by statutory or judicial law or hereinafter granted. Product names used in this document may be trademarks or registered trademarks of their respective companies and are hereby acknowledged. All non-ADJ Products, LLC brands and product names are trademarks or registered trademarks of their respective companies.

**ADJ Products, LLC** and all affiliated companies hereby disclaim any and all liabilities for property, equipment, building, and electrical damages, injuries to any persons, and direct or indirect economic loss associated with the use or reliance of any information contained within this document, and/or as a result of the improper, unsafe, insufficient and negligent assembly, installation, rigging, and operation of this product.

## DOCUMENT VERSION



Due to additional product features and/or enhancements, an updated version of this document may be available online.

Please check [www.adj.com](http://www.adj.com) for the latest revision/update of this manual before beginning installation and/or programming.

Date	Document Version	Software Version	DMX Channels	Notes
07/06/2023	1.0	1.01	6/9/10/12/15/18 Ch	Initial Release
08/15/2023	1.1	N/C	No Change	Updated marine coating to C3
09/01/2023	1.2	N/C	No Change	Updated Overview, Dimensional Drawings, Specifications.
09/29/2023	1.3	N/C	No Change	Corrected Color Macros Chart
10/12/2023	1.4	N/C	No Change	Updated Specifications; added FCC Statement

### Europe Energy Saving Notice

Energy Saving Matters (EuP 2009/125/EC)

Saving electric energy is a key to help protecting the environment. Please turn off all electrical products when they are not in use. To avoid power consumption in idle mode, disconnect all electrical equipment from power when not in use. Thank you!

# TABLE OF CONTENTS

<b>Introduction</b>	<b>4</b>
<b>Limited Warranty (USA Only)</b>	<b>5</b>
<b>Warranty Registration   Features</b>	<b>6</b>
<b>IP65 Rated</b>	<b>7</b>
<b>Safety Precautions</b>	<b>8</b>
<b>Overview</b>	<b>9</b>
<b>Installation</b>	<b>10</b>
<b>Accessory Installation</b>	<b>15</b>
<b>Wireless Setup</b>	<b>17</b>
<b>Remote Device Management (RDM)</b>	<b>18</b>
<b>Control Panel</b>	<b>19</b>
<b>System Menu</b>	<b>20</b>
<b>Operational Modes</b>	<b>23</b>
<b>DMX Set Up</b>	<b>25</b>
<b>DMX Traits</b>	<b>27</b>
<b>Color Macros Chart</b>	<b>30</b>
<b>Dim Speeds</b>	<b>32</b>
<b>Dim Modes</b>	<b>33</b>
<b>Primary-Secondary Set Up   Multi Unit Power Linking</b>	<b>34</b>
<b>Maintenance Guidelines</b>	<b>35</b>
<b>Torque Settings for Screws</b>	<b>36</b>
<b>Dimensional Drawings</b>	<b>38</b>
<b>Specifications</b>	<b>41</b>
<b>Optional Accessories   Error Codes   FCC Statement</b>	<b>42</b>

# INTRODUCTION

**Unpacking:** Thank you for purchasing the Encore LP12Z IP by ADJ Products, LLC. Every device has been thoroughly tested and has been shipped in perfect operating condition. Carefully check the shipping carton for damage that may have occurred during shipping. If the carton appears to have been damaged, carefully inspect your fixture for any damage and be sure all accessories necessary to operate the unit have arrived intact. In the event that damage has been found or parts are missing, please contact our toll free customer support number for further instructions. Do not return this unit to your dealer without first contacting customer support.

**Introduction:** The ADJ Encore LP12Z IP is an IP65-rated wash fixture with motorized zoom, wireless DMX and a variety of useful professional control tools for staging and event application. Its twelve 20W Quad RGBL (Red, Green, Blue and Lime) LEDs allow for a wide array of colors to be produced, tunable white color control from 2700K to 6500K and an attractive CRI output. **This product is intended to be used by professionally trained personnel only and is not suitable for private use.**

**Customer Support:** Contact ADJ Service for any product related service and support needs. Also visit [forums.adj.com](http://forums.adj.com) with questions, comments or suggestions.

**Parts:** To purchase parts online visit:

<http://parts.adj.com> (US)

<http://www.adjparts.eu> (EU)

**ADJ SERVICE USA - Monday - Friday 8:00am to 4:30pm PST**

**Voice: 800-322-6337 | Fax: 323-582-2941 | [support@adj.com](mailto:support@adj.com)**

**ADJ SERVICE EUROPE - Monday - Friday 08:30 to 17:00 CET**

**Voice: +31 45 546 85 60 | Fax: +31 45 546 85 96 | [support@adj.eu](mailto:support@adj.eu)**

## **ADJ PRODUCTS LLC USA**

6122 S. Eastern Ave. Los Angeles, CA. 90040

323-582-2650 | Fax 323-532-2941 | [www.adj.com](http://www.adj.com) | [info@adj.com](mailto:info@adj.com)

## **ADJ SUPPLY Europe B.V**

Junostraat 2 6468 EW Kerkrade, The Netherlands

+31 (0)45 546 85 00 | Fax +31 45 546 85 99

[www.americandj.eu](http://www.americandj.eu) | [info@americandj.eu](mailto:info@americandj.eu)

## **ADJ PRODUCTS GROUP Mexico**

AV Santa Ana 30 Parque Industrial Lerma, Lerma, Mexico 52000

+52 (728) 282-7070

**CAUTION!** There are no user serviceable parts inside this unit. Do not attempt any repairs yourself, as doing so will void your manufacturer's warranty. In the unlikely event your unit may require service, please contact ADJ Products, LLC.

*Do not discard the shipping carton in the trash. Please recycle when ever possible.*

# LIMITED WARRANTY (USA ONLY)

- A. ADJ Products, LLC hereby warrants, to the original purchaser, ADJ Products, LLC products to be free of manufacturing defects in material and workmanship for a prescribed period from the date of purchase (see specific warranty period on reverse). This warranty shall be valid only if the product is purchased within the United States of America, including possessions and territories. It is the owner's responsibility to establish the date and place of purchase by acceptable evidence, at the time service is sought.
- B. For warranty service, you must obtain a Return Authorization number (RA#) before sending the product back—please contact ADJ Products, LLC Service Department at 800-322-6337. Send the product only to the ADJ Products, LLC factory. All shipping charges must be prepaid. If the requested repairs or service (including parts replacement) are within the terms of this warranty, ADJ Products, LLC will pay return shipping charges only to a designated point within the United States. If the entire instrument is sent, it must be shipped in its original package and packaging material. No accessories should be shipped with the product. If any accessories are shipped with the product, ADJ Products, LLC shall incur no liability whatsoever for loss of or damage to any such accessories, nor for the safe return thereof.
- C. This warranty is void if the product serial number and/or labels are altered or removed; if the product is modified in any manner which ADJ Products, LLC concludes, after inspection, affects the reliability of the product; if the product has been repaired or serviced by anyone other than the ADJ Products, LLC factory unless prior written authorization was issued to purchaser by ADJ Products, LLC; if the product is damaged because it was not properly maintained as set forth in the product instructions, guidelines and/or user manual.
- D. This is not a service contract, and this warranty does not include maintenance, cleaning, or periodic check-up. During the period specified above, ADJ Products, LLC will replace defective parts at its expense with new or refurbished parts, and will absorb all expenses for warranty service and repair labor by reason of defects in material or workmanship. The sole responsibility of ADJ Products, LLC under this warranty shall be limited to the repair of the product, or replacement thereof, including parts, at the sole discretion of ADJ Products, LLC. All products covered by this warranty were manufactured after August 15, 2012, and bear identifying marks to that effect.
- E. ADJ Products, LLC reserves the right to make changes in design and/or improvements upon its products without any obligation to include these changes in any products theretofore manufactured.
- F. No warranty, whether expressed or implied, is given or made with respect to any accessory supplied with products described above. Except to the extent prohibited by applicable law, all implied warranties made by ADJ Products, LLC in connection with this product, including warranties of merchantability or fitness, are limited in duration to the warranty period set forth above. And all warranties, whether expressed or implied, including warranties of merchantability or fitness, are limited in duration to the warranty period set forth above. The consumer's and/or dealer's sole remedy shall be such repair or replacement as is expressly provided above; and under no circumstances shall ADJ Product, LLC be liable for any loss and/or damage, direct and/or consequential arising out of the use of, and/or inability to use this product.
- G. This warranty is the only written warranty applicable to ADJ Products, LLC products, and supersedes all prior warranties and written descriptions of warranty terms and conditions heretofore published.

## MANUFACTURER'S LIMITED WARRANTY PERIODS:

- Non-LED Lighting Products = 1-Year (365 Days) (Including Special Effect Lighting, Intelligent Lighting, UV lighting, Strobes, Fog Machines, Bubble Machines, Mirror Balls, Par Cans, Trussing, Lighting Stands, Power/Data Distribution, etc. excluding LED and lamps)
- Laser Products = 1-Year (365 Days) (excluding laser diodes which have a 6-Month Limited Warranty)
- LED Products = 2-Year (730 Days) (excluding batteries which have a 180 Day Limited Warranty)
- NOTE: 2-Year (730 Days) Limited Warranty ONLY applies to product purchased within the United States. StarTec Series = 1-Year (365 Days) (excluding batteries which have a 180 Day Limited Warranty)
- ADJ DMX Controllers = 2 Year (730 Days)
- American Audio Products = 1 Year (365 Days)

# WARRANTY REGISTRATION

Please fill out the enclosed warranty card to validate your purchase. All returned service items, whether under warranty or not, must be freight pre-paid and accompanied by a return authorization (R.A.) number. The R.A. number must be clearly written on the outside of the return package. A brief description of the problem as well as the R.A. number must also be written down on a piece of paper included in the shipping carton. If the unit is under warranty, you must provide a copy of your proof of purchase invoice. You may obtain an R.A. number by contacting our customer support team. All packages returned to the service department not displaying an R.A. number on the outside of the package will be returned to the shipper.

## FEATURES

- IP65 Rating for Temporary Outdoor and Indoor Events
- 12 x 20W Quad RGBL (Red, Blue, Green, Lime) LEDs
- 64 Built-In Color Macros
- Tunable White Control with Five (5) Preset Color Temperatures
- Motorized Zoom Feature
- Wireless DMX Onboard
- RDM Compatible
- 6 Selectable Dimming Modes
- 4 Selectable Dim Curves
- Adjustable Refresh Rates and Flicker-Free Operation

## INCLUDED ITEMS

- Power Cable (x1)

# IP65 RATED

The **International Protection (IP)** rating system is commonly expressed as “**IP**” (Ingress Protection) followed by two numbers (i.e. IP65), where the numbers define the degree of protection. The first digit (Foreign Bodies Protection) indicates the extent of protection against particles entering the fixture, and the second digit (Water Protection) indicates the extent of protection against water entering the fixture. An **IP65** rated lighting fixture is designed and tested to protect against the ingress of dust (6), and low-pressure water jets from any direction (5).

**NOTE: THIS FIXTURE IS INTENDED FOR TEMPORARY OUTDOOR USE ONLY!**

**Maritime/Coastal Environment Installations:** A coastal environment is seaside adjacent, and caustic to electronics through exposure to atomized salt-water and humidity, whereas maritime is anywhere within 5-miles of a coastal environment.



**NOT suitable for maritime/coastal environment installations. Installing this fixture in a maritime/coastal environment may cause corrosion and/or excessive wear to the interior and/or exterior components of the fixture. Damages and/or performance issues resulting from installation in a maritime/coastal environment will void the manufactures warranty, and will NOT be subject to any warranty claims and/or repairs.**

Maritime installations require additional preparation, and additional service intervals may be needed given the maritime use. In general, IP ratings presuppose freshwater conditions VS maritime conditions, which are typically more “caustic” to IP fixtures (both internally and externally). A duty-cycle may also be needed when units are not in use. During times of high humidity and colder temperatures, condensation may occur internally so the fixture may require a duty-cycle to bring it up to running temperature, allowing any accumulation of moisture to be expelled via the vent valve. Recommendations can change based on installation environmental circumstances. A waterproof dome or similar device is recommended for use in permanent outdoor installations. When using a dome, refer to manufacturer recommendations for duty-cycle.

**NOTE: NOT ALL FEATURES LISTED ARE AVAILABLE ON ALL FIXTURES; THE FOLLOWING INSTRUCTIONS MAY NOT APPLY. CONTACT SUPPORT FOR ADDITIONAL DETAILS.**

**Exterior Maintenance:** Inspect the exterior every 30-days. The unit must be powered off/disconnected. Inspect optics to determine if the lens is obstructed, then clean optics and chassis accordingly. Based on initial finding, schedule maintenance accordingly, keeping in mind that exterior maintenance will be required. Even if the luminaires are NOT in use, maintenance will still be needed given its location (exterior use). The use of a durable type of wax on the chassis is recommended since it will help prevent contaminant build up. Inspect both power and data lines for any signs of contaminants or corrosion. Periodically reapplying di-electric grease, especially in coastal environments. If any signs of corrosion/contaminants are present, clean thoroughly, and/or replace connectors, then reapply di-electric grease. Typically, this should be done annually, or any time an opportunity presents itself. As a preventive measure, annual replacement of both vent valves is recommended. The vent valve membrane can become contaminated and/or clogged causing improper venting of humidity within the luminaire. Inspect all mounting hardware as a precaution.

**Interior Maintenance:** Inspect the interior every 30-days. The unit must be powered off/disconnected.

- Inspect zoom/focus mechanism, clean optics, lubricate linear bearings (Krytox oil) as needed, inspect belts for wear
- Inspect all rotating effect wheels, manually rotate them, note any resistance
- Inspect all remaining rotating belts for any wear
- Inspect all fans, clean as needed, check rotation, check connections
- Inspect CMY module, manually move flags and check for signs of resistance, and if needed, clean guide rods first, then reapply a thin layer of grease (moly lube)
- Clean interior with low-volume compressed air, then clean optics prior to reassembly of head covers

Although the base has limited moving parts, the pan belt should also be inspected for wear. Remember to always perform an IP test anytime a cover is removed.

There is no specific time frame regarding the routine replacement of parts such as belts/stepper motors, PCBs, or LEDs. These items should only be replaced on an as needed bases, except for cooling fans, which should be replaced once the luminaries reach 10,000-hours. This is a prophylactic measure intended to keep the unit running as cool as possible, insuring proper function of all internal components. A complete service breakdown is available, please contact [service@adj.com](mailto:service@adj.com) for any needed parts or manuals.

# SAFETY PRECAUTIONS



**PROTECTION CLASS 1 - FIXTURE MUST BE PROPERLY GROUNDED.**



**THERE ARE NO USER SERVICEABLE PARTS INSIDE THIS UNIT. DO NOT ATTEMPT ANY REPAIRS YOURSELF, AS DOING SO WILL VOID YOUR MANUFACTURER'S WARRANTY. DAMAGES RESULTING FROM MODIFICATIONS TO THIS FIXTURE AND/OR THE DISREGARD OF SAFETY INSTRUCTIONS AND GUIDELINES IN THIS MANUAL VOID THE MANUFACTURER'S WARRANTY AND ARE NOT SUBJECT TO ANY WARRANTY CLAIMS AND/OR REPAIRS.**



**NEVER LOOK DIRECTLY INTO THE LIGHT SOURCE!  
RETINA INJURY RISK - MAY INDUCE BLINDNESS!  
SENSITIVE PERSONS MAY SUFFER AN EPILEPTIC SHOCK!**

- **Maximum ambient operating temperature is 113° F (45° C)!**
- DO NOT TOUCH the fixture housing during operation. Disconnect the power and allow approximately 15 minutes for the fixture to cool down before servicing.
- DO NOT shake the fixture, and avoid brute force when installing and/or operating the fixture.
- DO NOT operate the fixture if the power cord has become frayed, crimped and/or damaged. If the power cord is damaged, replace immediately with a new one of the same power rating.
- DO NOT attempt to remove or break off the ground prong from the electrical cord. This prong is used to reduce the risk of electrical shock and fire in case of an internal short.
- DO NOT attempt to operate this unit if it has been damaged in any way.
- Disconnect from main power before making any type of connection.
- DO NOT block any air ventilation slots. All fan and air inlets must remain clean and never blocked. Allow approx. 6" (15cm) between fixture and other devices or a wall for proper cooling.
- Always be sure to mount this unit in an area that will allow proper ventilation. Allow about 6" (15cm) between this device and a wall.
- DO NOT remove the cover for any reason.
- When installing fixture in a suspended environment, always use mounting hardware that is no less than M10 x 25mm, and always install fixture with an appropriately rated safety cable.
- Never plug this unit in to a dimmer pack.
- During long periods of non-use, disconnect the unit's main power.
- Always mount this unit in safe and stable matter.
- Power-supply cords should be routed so that they are not likely to be walked on or pinched by items placed upon or against them, paying particular attention to the point where they exit from the unit.
- Cleaning - The fixture should be cleaned only as recommended by the manufacturer.
- Heat - The appliance should be situated away from heat sources such as radiators, heat registers, stoves, or other appliances (including amplifiers) that produce heat.
- The fixture should be serviced by qualified service personnel when:
  - A. The power-supply cord or the plug have been damaged.
  - B. Objects have fallen onto the fixture.
  - C. The fixture does not appear to operate normally or exhibits a marked change in performance.
  - D. The fixture has fallen and/or has been subjected to extreme handling.

# OVERVIEW

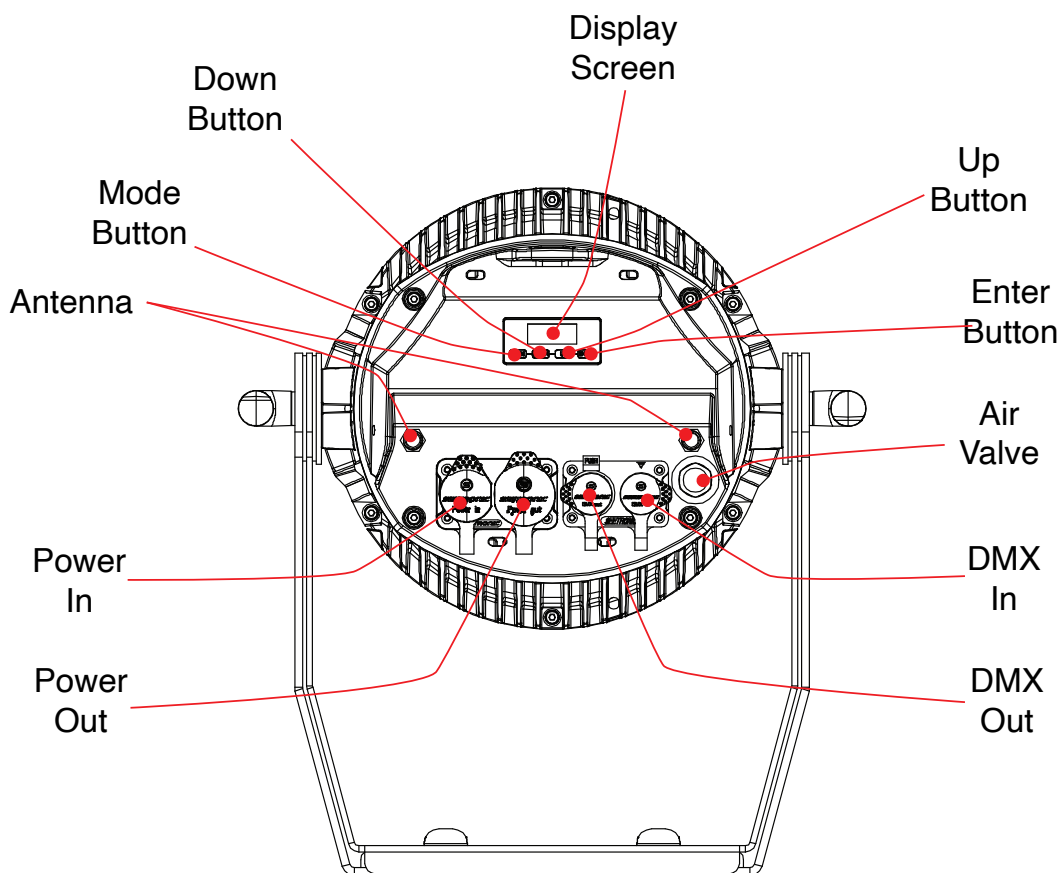
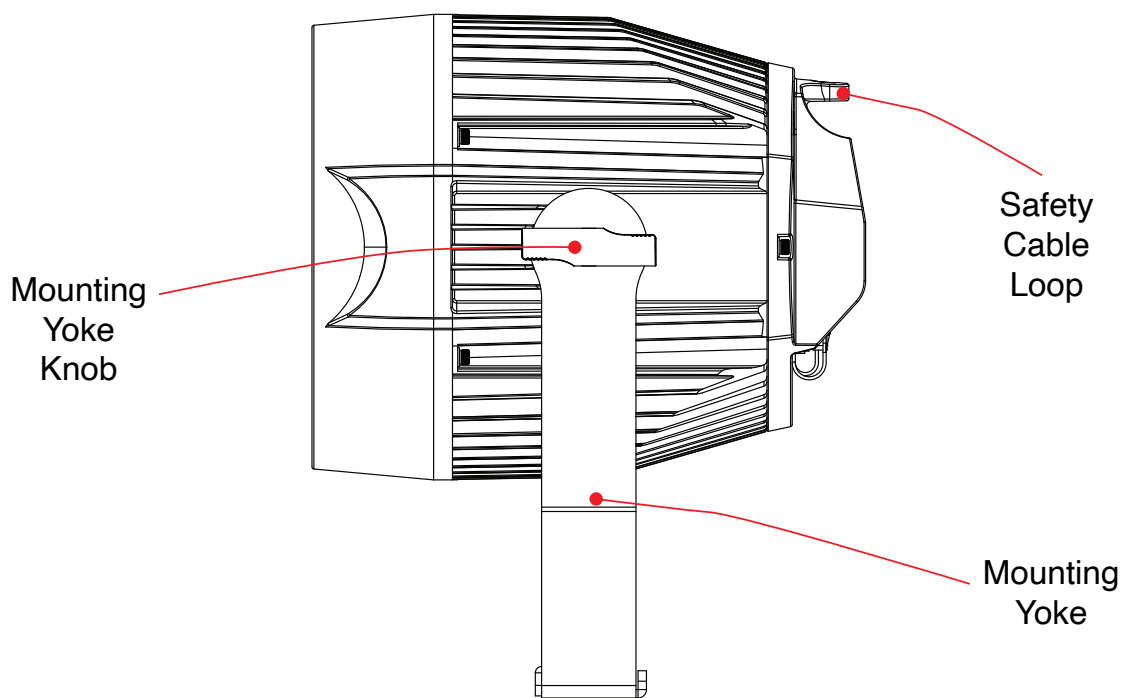

# INSTALLATION



**DO NOT INSTALL THE FIXTURE IF YOU ARE NOT QUALIFIED TO DO SO!**

Fixture **MUST** be installed following all local, national, and country commercial electrical and construction codes and regulations.

When installing the unit, the trussing or area of installation must be able to hold 10 times the weight of the unit and any attached accessories without any deformation. The unit must be secured with a secondary safety attachment, e.g. an appropriately-rated safety cable.

Before rigging/mounting a single fixture to any metal truss/structure or placing the fixture(s) on any surface, a professional equipment installer **MUST** be consulted to determine if the metal truss/structure or surface is properly certified to safely hold the combined weight of the fixture(s), clamps, cables, and accessories.

Maximum ambient operating temperature is **113°F (45°C)**.

Fixture(s) should be installed away from walking paths, seating areas, or areas where unauthorized personnel might reach the fixture by hand.

**NEVER** stand directly below the fixture(s) when rigging, removing, or servicing.

Overhead fixture installation must always be secured with a secondary safety attachment, such as an appropriately rated safety cable that can hold 10 times the weight of the fixture.

Overhead mounting requires extensive experience, including calculating working load limits, knowledge of installation material being used, and periodic safety inspection of all installation material as well as the unit itself. If you lack these qualifications, do not attempt the installation yourself.

The installation should be checked by a skilled person once a year.

# INSTALLATION

## CLAMP MOUNTING

This fixture features two mounting holes for the attachment of an Omega bracket, which are located on the adjustable mounting yoke. Insert the Omega bracket's twist lock fasteners into these two mounting holes, then twist to secure in place. When mounting the fixture to a truss or any other suspended structure, be sure to secure an appropriate rated clamp (not included) to the Omega bracket. Insert a bolt of appropriate size through the bottom of the mounting clamp and the central hole on the Omega bracket, and secure them together with a matching nut. Additionally, the unit also features a safety cable loop on the rear panel (see the illustration below). Attach a separate **SAFETY CABLE** of the appropriate weight rating to the provided safety cable loop, then secure the other end to a suitable mounting point.

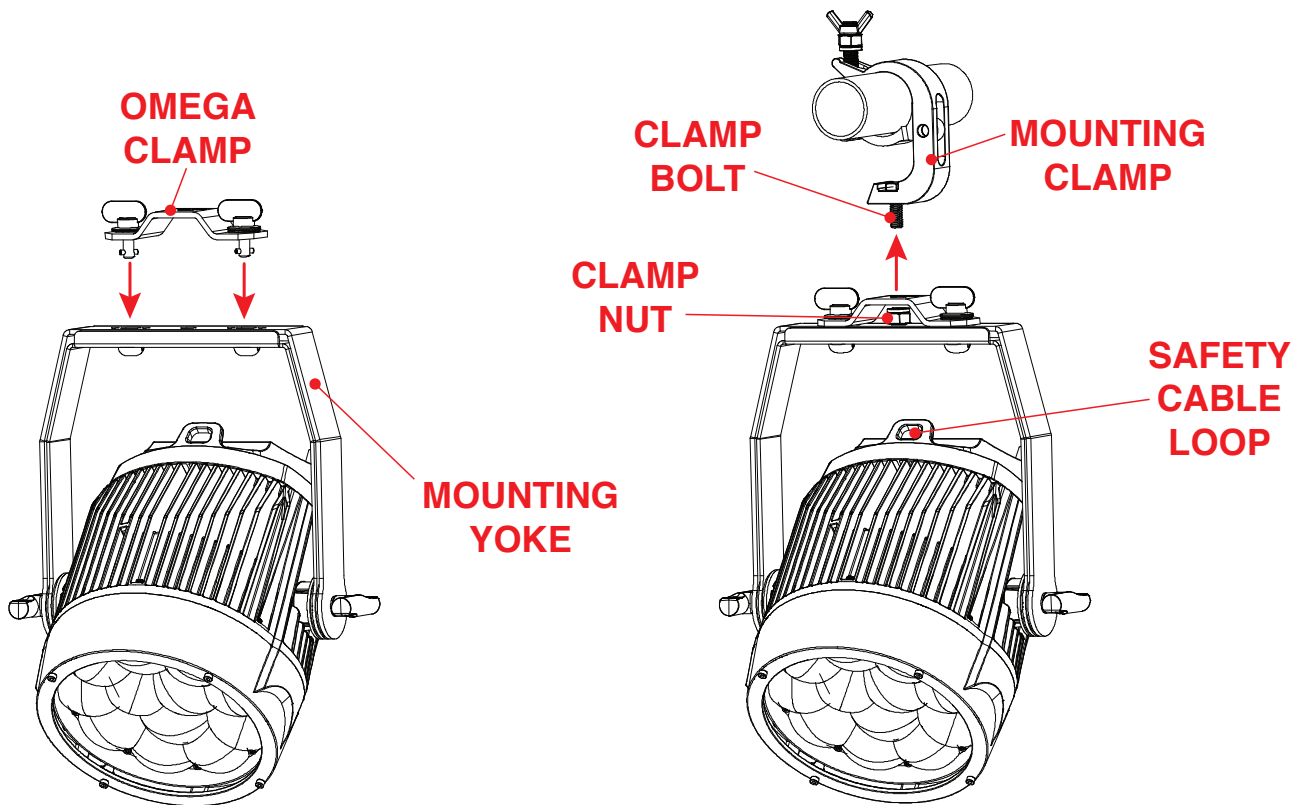

### SAFETY CABLE:



**ALWAYS ATTACH A SAFETY CABLE WHENEVER INSTALLING THIS FIXTURE IN A SUSPENDED ENVIRONMENT TO ENSURE THAT THE FIXTURE WILL NOT FALL IF THE CLAMP FAILS.**

# INSTALLATION

## STAND MOUNTING

This unit can also be installed atop a tripod stand. Simply secure the Omega bracket to the bottom face of the device, then insert the threaded bolt on the top of the tripod stand through the hole in the Omega bracket. Tighten the nut onto the threaded bolt to secure the mounted device in place.

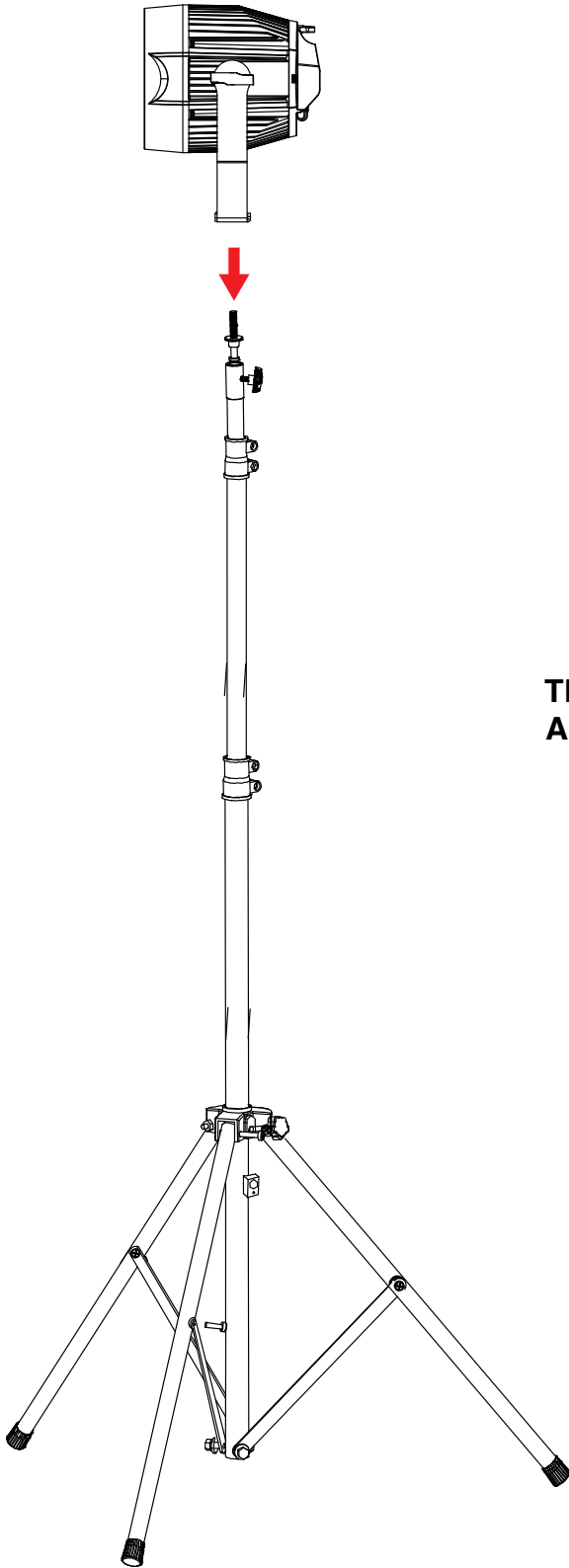

**CAUTION!**

**MAKE SURE THAT THE TRIPOD LEGS AND ALL TELESCOPING ELEMENTS OF THE TRIPOD STAND ARE LOCKED IN PLACE BEFORE INSTALLING THE DEVICE ATOP THE STAND!**

**POSITION THE TRIPOD STAND AND MOUNTED DEVICE ONLY ON FLAT, STABLE SURFACES!  
DEPLOY TRIPOD LEGS FULLY IN ORDER TO MAXIMIZE STABILITY!**

# INSTALLATION

## POTENTIAL INTERNAL FIXTURE DAMAGE FROM EXTERNAL SOURCES OF LIGHT BEAMS

External sources of light beams from direct sunlight, lighting and moving head fixtures, and lasers, which are focused directly towards the exterior housing and/or penetrate the front lens opening of ADJ lighting fixtures, can cause severe internal damage including burning of optics, dichroic color filters, glass and metal gobos, prisms, animation wheels, frost filters, iris, shutters, motors, belts, wiring, discharge lamps, and LEDs.

This issue is not specific only to ADJ lighting fixtures, but rather it is a common issue with lighting fixtures from all manufacturers. Although there is no true way to fully prevent this issue from happening, the guidelines below can reduce the risk of potential damage. Contact ADJ Service for more details.

**DO NOT EXPOSE THE FIXTURE AND/OR FRONT LENS OPENING TO LIGHT BEAMS FROM DIRECT SUNLIGHT, OTHER LIGHTING OR MOVING HEAD FIXTURES, AND LASERS DURING UNPACKING, INSTALLATION, USE, AND EXTENDED IDLE TIMES OUTDOORS. DO NOT FOCUS A LIGHT BEAM FROM ONE LIGHTING FIXTURE DIRECTLY TOWARDS ANOTHER.**

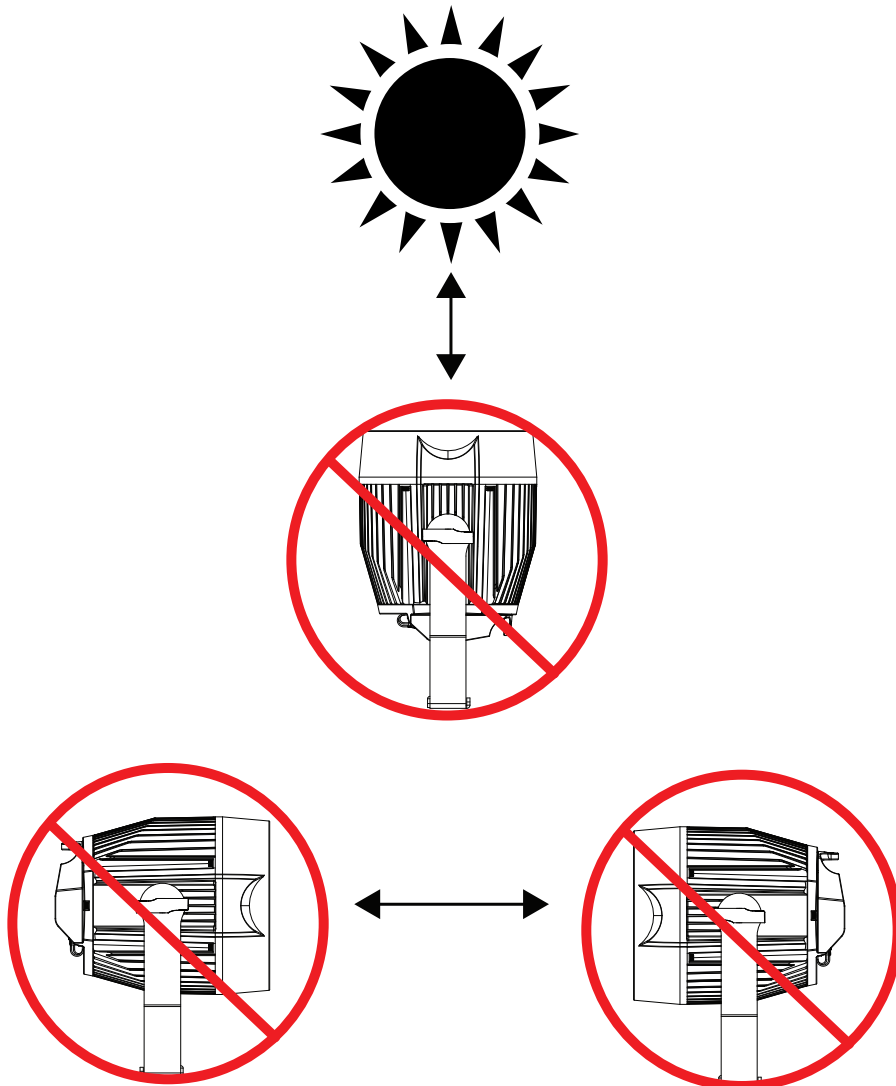

# INSTALLATION

**NOTICE:** The maximum ambient operational temperature for this lighting fixture is **113° F (45° C)**. Do not place this lighting fixture in an environment where the temperatures exceed this value. This will allow the fixture to run at its best and help prolong the fixture life.

**NOTE:** When this fixture is fitted with the optional barndoors and installed in a suspended setting, the fixture should be oriented with the gel frame holder latch upward, in order to minimize the risk of the barndoor falling in the event that the latch fails. See the Accessory Installation section for details.

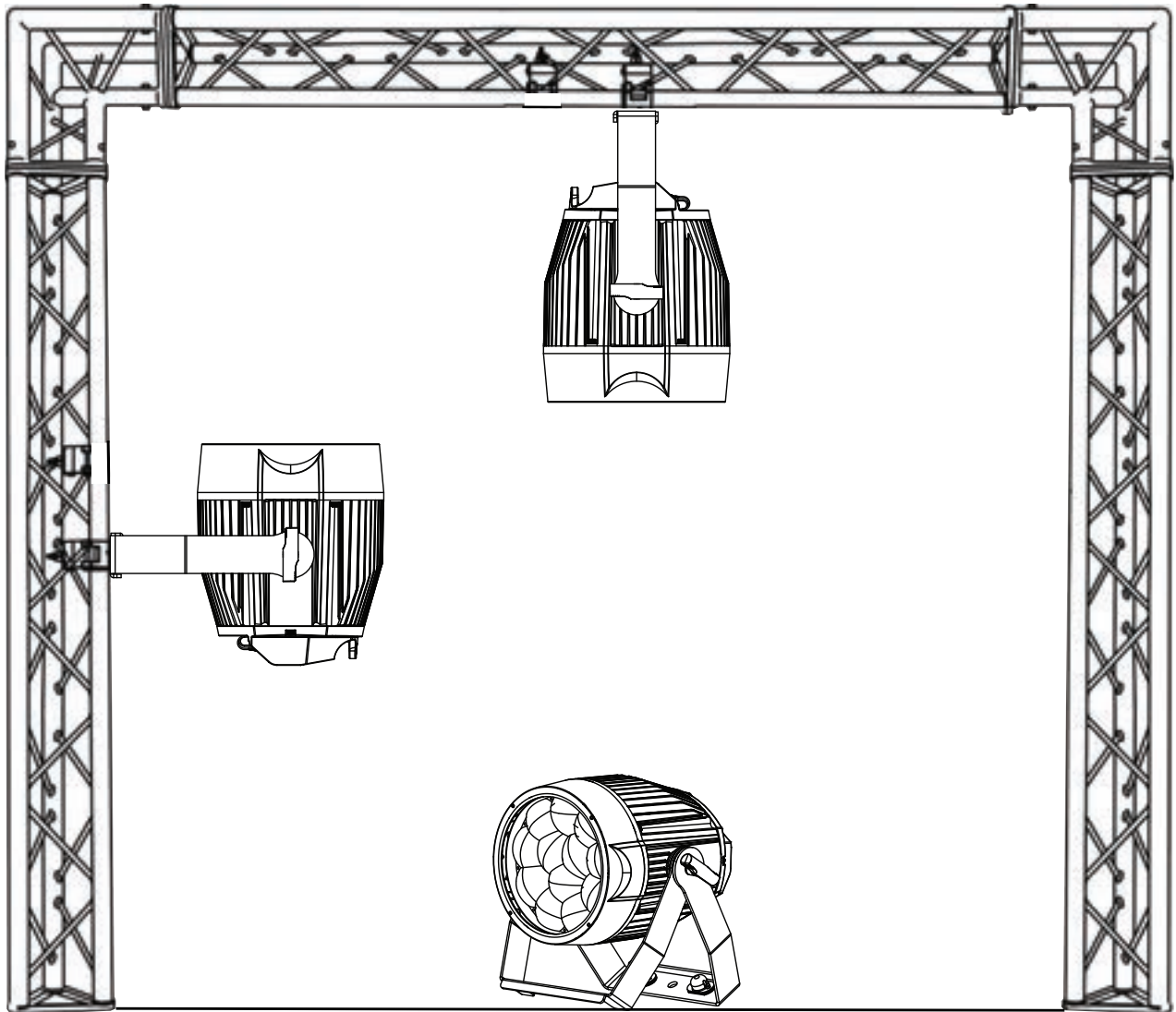

The unit is fully operational in three different mounting positions: hanging upside-down from the ceiling or trussing, sideways on trussing, or set on a flat level surface. Be sure this fixture is kept at least 12m (40ft) away from any flammable materials (decorations, etc). Always use and install a safety cable (not included) as a safety measure to prevent accidental damage and/or injury in the event the clamp fails. Never use the carrying handles for secondary attachment.

# ACCESSORY INSTALLATION

## GEL FRAME AND BARN DOORS

Available accessories include a gel frame and a set of barn doors, both of which can easily be installed using the fixture's detachable accessory mounting slot. Follow the instructions below:

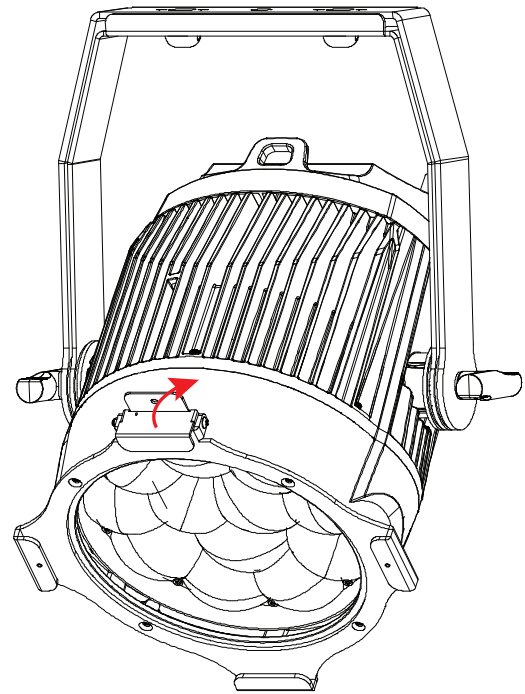
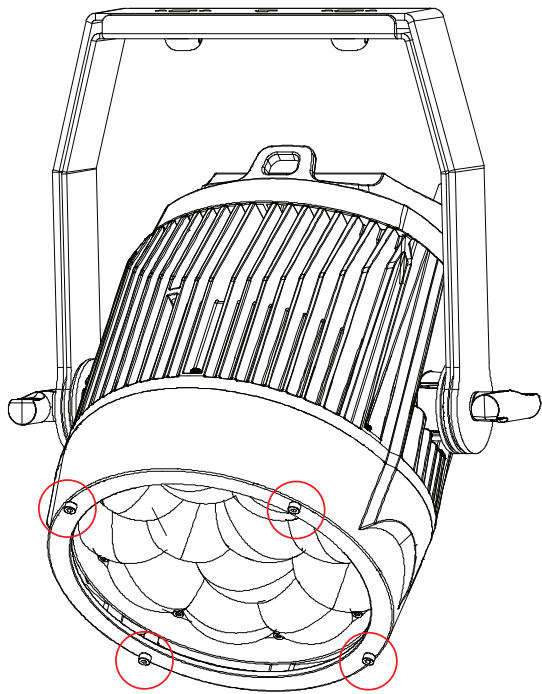

1. Remove the four (4) screws around the frame of the fixture's lens.
2. Align the gel frame holder on the frame, then re-install the four (4) screws to secure in place. Flip the latch open.

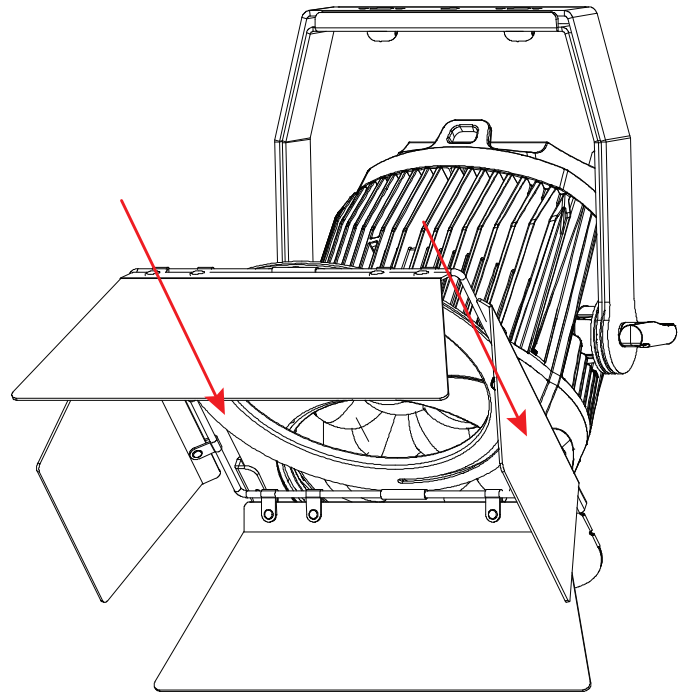
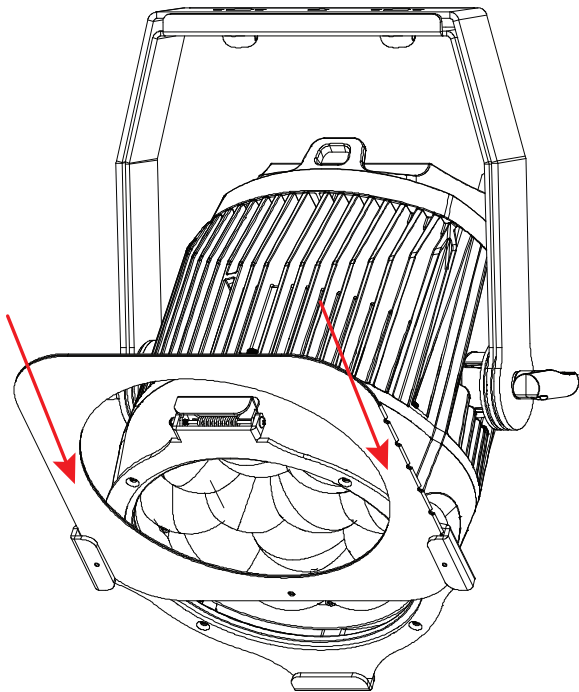

3. Slide the gel frame into gel frame holder's slot.
4. If desired, removed the barn door's included thumb screws, then slide the barn door into the slot in front of the gel frame.

# ACCESSORY INSTALLATION

## GEL FRAME AND BARN DOORS

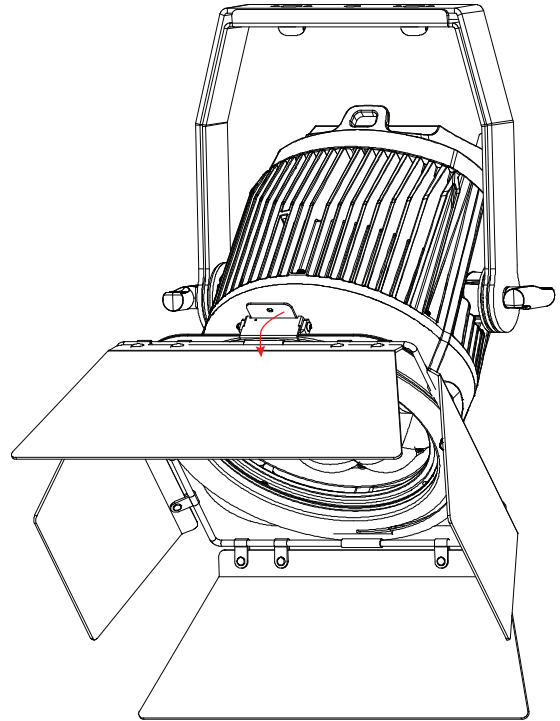
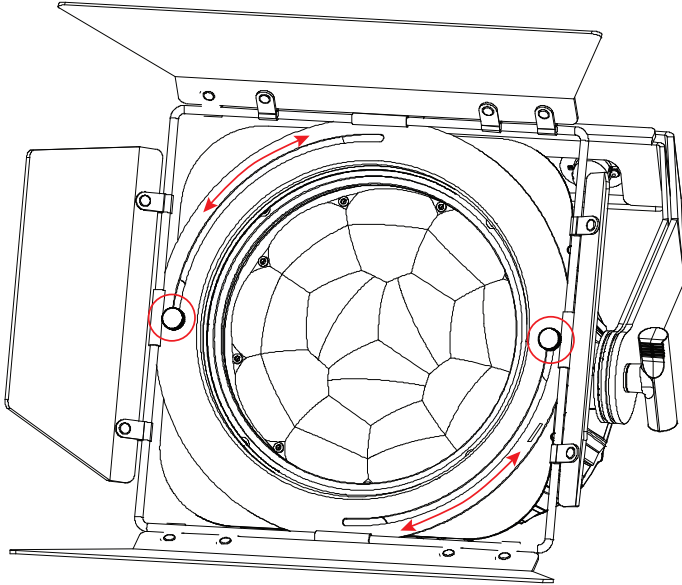

5. Align the semi-circular slots on the front of the barndoors with the two screw holes located on the tabs of the gel frame holder, and loosely re-install the included thumb screws. Twist the barndoors to adjust their position, then tighten the thumb screws to secure in place.

6. Flip the latch closed to secure the gel frame and barndoors in place.

**NOTE: WHEN FITTED WITH THE BARN-DOORS AND INSTALLED IN A SUSPENDED SETTING, THE FIXTURE MUST BE ORIENTED WITH THE GEL FRAME HOLDER LATCH UPWARD. THIS MINIMIZES THE RISK OF THE BARNDORR FALLING IN THE EVENT THAT THE LATCH FAILS.**

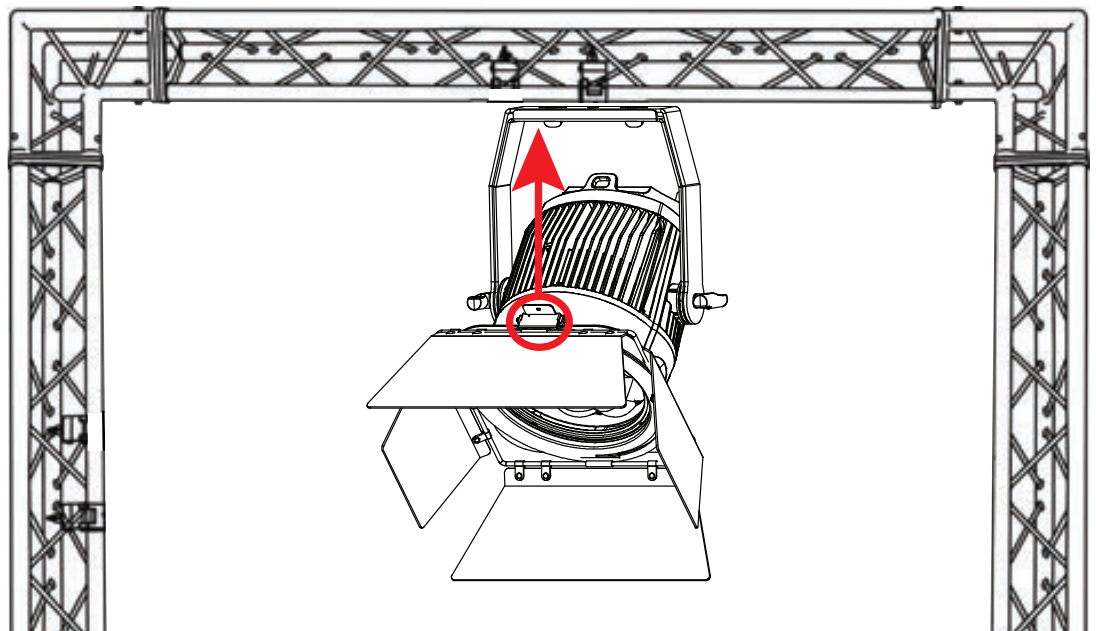

# WIRELESS SETUP

To set up wireless control, follow the steps below:

1. Navigate to Personality > Wireless Settings in the system menu. Press ENTER to select this menu.
2. Use UP and DOWN to scroll to “Wireless Settings” and press ENTER. Use UP and DOWN to scroll to the “On” option, then press ENTER to confirm. A green LED and signal strength indicator should illuminate to show that wireless is enabled and connected.
3. Return to the “Wireless Settings” sub-menu and scroll to “Set Wireless Channel.” Press ENTER, then use the UP and DOWN buttons to select the wireless channel that you would like this unit to operate on. Selectable values are from 00 to 14. Press ENTER to confirm.

There are many factors that can affect and/or interrupt a wireless signal, including walls, glass, metal, objects, and people. Therefore, the following guidelines are recommended in order to maximize the chances of having a clear path for the wireless signal to reach the device:

- Install the device a minimum of 9.8 ft (3m) above audiences and/or ground level.
- Arrange the wireless antenna in an upright, vertical position.
- Position devices in direct line of sight of the transmitting controller.

Careful planning and testing of the selected installation location is critical to ensure optimum and reliable wireless operation.

9.8 ft (3m)  
Above Ground



# REMOTE DEVICE MANAGEMENT (RDM)

**NOTE: In order for RDM to work properly, RDM enabled equipment must be used throughout the entire system, including DMX data splitters and wireless systems.**

Remote Device Management (RDM) is a protocol that sits on top of the DMX512 data standard for lighting, allowing the DMX systems of the fixtures to be modified and monitored remotely. This protocol is ideal for instances in which a unit is installed in a location that is not easily accessible.

With RDM, the DMX512 system becomes bi-directional, allowing a compatible RDM enabled controller to send out a signal to devices on the wire, as well as allowing the fixture to respond (known as a *GET* command). The controller can then use its *SET* command to modify settings that would typically have to be changed or viewed directly via the unit's display screen, including the DMX Address, DMX Channel Mode, and Temperature Sensors.

## FIXTURE RDM INFORMATION:

RDM Code	Device ID	Device Model ID	Personality ID
0x1900	003C	60	6Ch (1); 9Ch (2); 10Ch (3); 12Ch (4); 15Ch (5); 18Ch (6)

**Please be aware that not all RDM devices support all RDM features,** and therefore it is important to check beforehand to ensure that the equipment that you are considering includes all of the features that you require.

[0x1031] Preset Playback	[0x0400] Device Hours
[0x0122] Default Slot Value	[0x0015] Comms Status
[0x00C2] Boot Software Version Label	[0x0031] Status ID Description
[0x00C1] Boot Software Version ID	[0x0032] Clear Status ID
[0x0070] Product Detail ID List	[0x0401] Lamp Hours
[0x0030] Status Messages	[0x0402] Lamp Strikes
[0x0011] Proxied Device Count	[0x0403] Lamp State
[0x0200] Sensor Definition	[0x0404] Lamp Mode
[0x0201] Sensor Value	[0x0405] Device Power Cycles
[0x0080] Device Model Description	[0x0500] Display Invert
[0x0081] Manufacturer Label	[0x0501] Display Level
[0x0082] Device Label	[0x0603] Realtime Clock
[0x00E0] DMX Personality	[0x1010] Power State
[0x00E1] DMX Personality Description	[0x0020] Queued Message

# CONTROL PANEL

This unit features a display screen with a 4-button control pad, which can be used to easily adjust any device settings.

Pressing the MODE button will cycle through the various Main Menu options. When the desired Main Menu option is displayed on the screen, press the ENTER button to enter the sub-menu, then use the UP and DOWN buttons to scroll through sub-menu options. In some cases, there will be a second sub-menu that can be navigated in the same way.

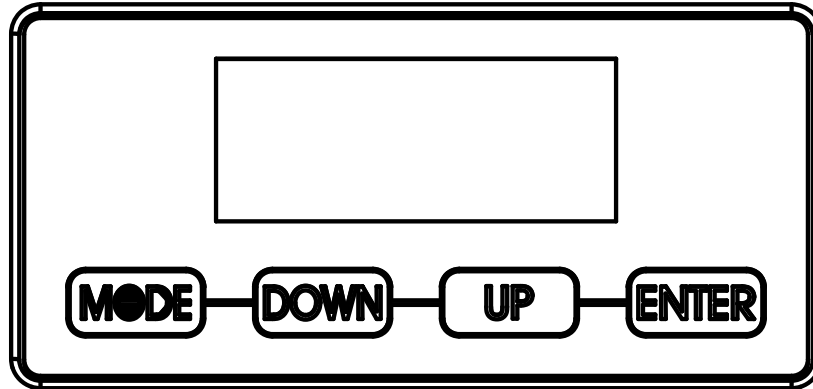

## SCREEN LOCK

The control panel screen will lock after a period of inactivity which can be set by navigating to Personality > Display > Lock. Default time is 30 seconds. To unlock the screen, press and hold the MODE button for 10 seconds.

# SYSTEM MENU

<b>DMX SET</b>	Address	<b>001</b> - 512		Set DMX address	
	Ch Mode	6Ch		Select DMX channel mode	
		9Ch			
		10Ch			
		<b>12Ch</b>			
		15Ch			
		18Ch			
	No DMX	<b>Hold</b>		Unit holds last DMX values received when signal is lost	
		Blackout		Unit takes all channels to DMX value of 0 when signal is lost	
		Manual		Unit defaults to last manual mode settings when signal is lost	
Int Prog		Unit default to selected internal program when signal is lost			
<b>PERSONALITY</b>	Prim / Sec Mode	Primary / <b>Secondary</b>		Set unit to primary or secondary mode	
	Select Signal	DMX or Wireless		DMX has priority; green LED when wireless connected, red LED when wireless not connected	
		Wireless and DMX Out		DMX XLR output shall send DMX signal out	
	Wireless Settings	Wireless Enable	On / <b>Off</b>		Enable or disable wireless
		Set Wireless Channel	<b>00</b> - 14		Select wireless channel

CONTINUED ON NEXT PAGE

# SYSTEM MENU

<b>PERSONALITY (continued)</b>	Zoom Mode	<b>Mode 1</b>		Zoom adjustment moves quickly	
		Mode 2		Slow zoom speed w/ minimal noise	
	Zoom Reset	Yes / <b>No</b>		Reset zoom	
	Dim Mode	<b>Standard</b>			Select dim mode
		Stage			
		TV			
		Archi			
		Theatre			
		Stage 2			
		Dim Speed	0.1s ~ 10.0s		Set dim delay time
	Dim Curve	<b>Square</b>			Select dim curve
		Linear			
		Inv Squa			
S Curve					
LED Rfrsh	900Hz, 1000Hz, 1100Hz, <b>1200Hz</b> , 1300Hz, 1400Hz, 1500Hz, 2500Hz, 4000Hz, 5000Hz, 10KHz, 15KHz, 20KHz, 25KHz			Select LED refresh rate	
Display	Save Dlay	1 - <b>10</b>		Set length of inactivity before screen display turns off	
	Lock	<b>Off</b> , 1min - 10min		Screen locks after selected period of inactivity	
Service	Calibrat Passcode = 050	Red 000 - 255		Calibration	
		Green 000 - 255			
		Blue 000 - 255			
		Lime 000 - 255			
	Restore Passcode = 011	<b>Yes / No</b>		Reset to factory default settings	
<b>MANUAL</b>	Red	<b>000 - 255</b>			Manual mode settings; please note that Color Macros will override manual settings
	Green	<b>000 - 255</b>			
	Blue	<b>000 - 255</b>			
	Lime	<b>000 - 255</b>			
	Clr Macro	<b>00 - 64</b>			
	Clr Temp	<b>000 - 255</b>			
	Clr Temp Macro	<b>000 - 255</b>			

CONTINUED ON NEXT PAGE

# SYSTEM MENU

<b>MANUAL (continued)</b>	Shutter	<b>000</b> - 255		Manual mode settings; please note that Color Macros will override manual settings
	Mastr Dim	<b>000</b> - 255		
	Zoom Line	<b>000</b> - 255		
	Zoom Pres	<b>000</b> - 255		
	Auto Prog	<b>000</b> - 255		
	Prog Spd	<b>000</b> - 255		
	Prog Fade	<b>000</b> - 255		
<b>INT PROGS</b>	Prog 0	Speed	000 - 255	Internal programs mode
		Fade	000 - 255	
	Prog 1	Speed	000 - 255	
		Fade	000 - 255	
	...	...	...	
	Prog 7	Speed	000 - 255	
		Fade	000 - 255	
<b>INFO</b>	Hours	Pwr On Hr1	xxxxxx Hours	Total lifetime hours fixture has been powered on
		Pwr On Hr2	xxxxxx Hours	Hours fixture has been powered on since last reset
		Pwr On Rst Passcode = 050	Yes / <b>No</b>	Reset Pwr On Hr2
	Temp	Current Temperature	xxx F / xxx C	Current fixture temp
		Max Temp 1	xxx F / xxx C	Max recorded temp since last reset
		Max Temp 2	xxx F / xxx C	Lifetime high recorded fixture temp
		Temp Rst Passcode = 050	Yes / <b>No</b>	Reset Max Temp 1
	Fan Info	Fan RPM	xxxx	Fan speed
	DMX Value	Red		Displays current DMX value of each setting
		Green		
		...		
		Auto Prog		
	Soft Vers	x.xx		Display current software version

# OPERATION MODES

This device features 4 different operation modes, plus a primary/secondary setting, all of which can be selected from the main system menu. These are easily configured and operated from the display screen and its control buttons. Follow the directions below to set up and operate each mode.

**STATIC COLOR MODE:** The unit will display a single pre-programmed color macro.

1. From the main menu, press UP and DOWN to navigate to “Manual Control”, then press ENTER to select.
2. Use the UP and DOWN buttons to scroll to the “Clr Macro” option, then press ENTER.
3. Use the UP and DOWN buttons to set “Clr Macro” to the desired value. Refer to the **Color Macros Chart** section of this manual for information about which colors are represented by each value. Press ENTER to confirm.

**RGBL DIMMER MODE:** The unit will display a single, custom mixed static color.

1. From the main system menu, press UP and DOWN to navigate to “Manual Control”, then press ENTER.
2. Use the UP and DOWN buttons to scroll through the following menu options: Red, Green, Blue, and Lime. Press ENTER to select the desired option.
3. Use the UP and DOWN button to select the desired value for the selected option, then press ENTER to confirm. Selectable values range from 000 to 255.
4. Press MODE to turn to the “Manual Control” menu, and repeat steps 2 and 3 for each color option. The unit should now steadily display the color mix that you have created.
5. Press MODE to return to the “Manual Control” menu, then use the UP and DOWN to scroll to the “Mastr Dim” option, and press ENTER to select.
6. Use the UP and DOWN buttons to set the dimmer, then press ENTER to confirm. Selectable values range from 000 to 255.

**PROGRAM MODE:** The unit will run a pre-configured program that is selected by the user. Speed and fade are adjustable.

1. From the main system menu, press UP and DOWN to navigate to “Int Progs”, then press ENTER.
2. Use the UP and DOWN buttons to scroll through the program options, from Program 0 through Program 7. The unit will preview the program shown on the display screen. Press ENTER to select the desired program.
3. Use the UP and DOWN button to scroll to “Speed” and press ENTER to select this option. Use the UP and DOWN buttons to set the speed at which the unit will cycle through the steps of the selected program. 0 is the slowest, and 255 is the fastest. Press ENTER to confirm.
4. Use the UP and DOWN button to scroll to “Fade” and press ENTER to confirm. Use the UP and DOWN buttons to set how gradually you want the unit each step of the selected program to fade in and out. 0 has no fade at all, 1 has a least fade, and 255 has the most. Press ENTER to confirm.

# OPERATION MODES

**DMX CONTROL MODE:** Control the unit using a DMX controller.

1. Use a DMX cable to connect the output port of your DMX controller to the DMX Input port of your first fixture. If multiple units will be running off the controller, then connect the DMX Output port of your first fixture to the DMX Input port of the next fixture, continuing until all fixtures are daisy-chained together via their DMX Input and Output ports. Refer to the **DMX Setup** section of this manual for detailed information about DMX connections.
2. From the main system menu, press UP and DOWN to navigate to “DMX Settings”, then press ENTER.
3. Use the UP and DOWN buttons to scroll to the “Address” option, then scroll to the desired channel and press ENTER to confirm. This channel represents the channel at which the fixture will begin to listen to the DMX signal.
  - If you want all of your fixtures to react in the same way, then all fixtures should be set to the same DMX starting address.
  - If you want each of your fixtures to react differently, then each fixture’s DMX address that is spaced apart from the previous fixture’s DMX address by the number of DMX channels that the fixtures have been set to run. For example, when running in a mode with 6 DMX channels, unit addresses should be set to 1, 7, 13, 19, etc.

For detailed information, please refer to the **DMX Setup** section of this manual.

4. Use the UP and DOWN buttons to scroll to the “Ch Mode” option, and select the DMX channel mode that you would like the fixture to operate in. Press ENTER to confirm. Please refer to the **DMX Traits** section of this manual for detailed information.
5. Use the UP and DOWN buttons to scroll to the “No DMX” option, then press SETUP to select. Use the UP and DOWN buttons to select the option for how you would like the unit to behave when DMX signal is lost or interrupted, then press ENTER to confirm. Please refer to the **System Menu** section for detailed descriptions of each option.

**PRIMARY-SECONDARY MODE:** This function allows you to link units together to run in a Primary-Secondary set-up, in which one unit will act as the controlling unit and the others will react to the controlling unit’s built-in programs. Any unit can be configured to act as a Primary or as a Secondary, but only one unit in a given system can be programmed to act as the Primary.

1. Daisy chain your units via the XLR connectors on the rear panels of each unit. Use standard XLR data cables to link your units together. Remember that the male XLR connector is the input and the female XLR connector is the output. The first unit in the chain (primary) will use the female XLR connector only. The last unit in the chain will use the male XLR connector only.
2. From the main system menu, use the UP and DOWN buttons to scroll to “Personality”, then press ENTER.
3. Use the UP and DOWN buttons to scroll to “Prim/Sec Mode”, and press ENTER.
4. The fixture can be set to Primary or Secondary. Use the UP and DOWN buttons to select one or the other, depending on which mode you would like the current fixture to use, then press ENTER to confirm.
5. Repeat steps 2 to 4 for each linked unit. Make sure that only one unit is designated as the Primary, while all other units are designated as Secondaries. The secondary units will act in conjunction with the primary unit.

# DMX SET UP

**DMX-512:** DMX is short for Digital Multiplex. This is a universal protocol used as a form of communication between intelligent fixtures and controllers. A DMX controller sends DMX data instructions from the controller to the fixture. DMX data is sent as serial data that travels from fixture to fixture via the DATA “IN” and DATA “OUT” XLR terminals located on all DMX fixtures (most controllers only have a DATA “OUT” terminal).

**DMX Linking:** DMX is a language allowing all makes and models of different manufacturers to be linked together and operate from a single controller, as long as all fixtures and the controller are DMX compliant. To ensure proper DMX data transmission, try to use the shortest cable path possible when linking several DMX fixtures. The order in which fixtures are connected in a DMX line does not influence the DMX addressing. For example, a fixture assigned a DMX address of 1 may be placed anywhere in a DMX line: at the beginning, at the end, or anywhere in the middle. When a fixture is assigned a DMX address of 1, the DMX controller knows to send DATA assigned to address 1 to that unit, no matter where it is located in the DMX chain.

**Data Cable (DMX Cable) Requirements (For DMX Operation):** This unit can be controlled via DMX-512 protocol. The DMX address is set on the rear panel of the unit. Your unit and your DMX controller require a standard 5-pin XLR connector for data input and data output. We recommend Accu-Cable DMX cables. If you are making your own cables, be sure to use standard 110-120 Ohm shielded cable (This cable may be purchased at almost all pro lighting stores). Your cables should be made with a male XLR connector at one end and a female XLR connector at the other. Also remember that DMX cable must be daisy chained and cannot be split.

**Notice:** Be sure to follow the illustration below when making your own cables. Do not use the ground lug on the XLR connector. Do not connect the cable’s shield conductor to the ground lug or allow the shield conductor to come in contact with the XLR’s outer casing. Grounding the shield could cause a short circuit and erratic behavior.

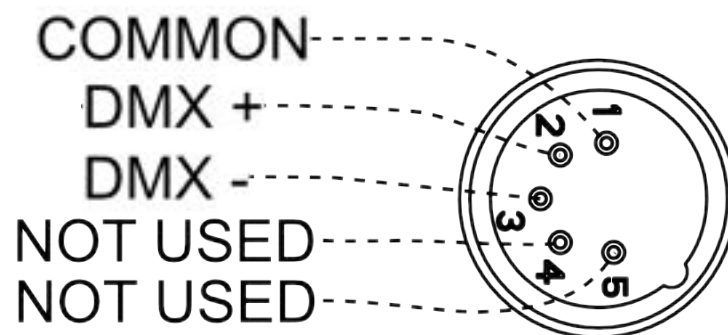

# DMX SET UP

**Special Note: Line Termination.** When longer runs of cable are used, you may need to use a terminator on the last unit to avoid erratic behavior. A terminator is a 110-120 ohm 1/4 watt resistor which is connected between pins 2 and 3 of a male XLR connector (DATA + and DATA -). This unit is inserted in the female XLR connector of the last unit in your daisy chain to terminate the line. Using a cable terminator (ADJ part number Z-DMX/T) will reduce the risk of erratic behavior.

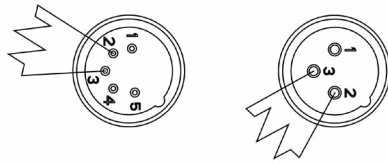

A DMX512 terminator reduces signal errors, avoiding most signal reflection interference. Connect PIN 2 (DMX-) and PIN 3 (DMX+) of the last fixture in series with a 120 Ohm, 1/4 W Resistor to terminate the DMX512.

## DMX ADDRESSING.

All fixtures should be given a DMX starting address when using a DMX controller, so the correct fixture responds to the correct control signal. This digital starting address is the channel number from which the fixture starts to “listen” to the digital control signal sent out from the DMX controller. The assignment of this starting DMX address is achieved by setting the correct DMX address on the digital control display on the fixture.

You can set the same starting address for all fixtures or a group of fixtures, or set different addresses for each individual fixture. Setting all fixtures to the same DMX address will cause all fixtures to react in the same way. In other words, changing the settings of one channel will affect all the fixtures simultaneously.

If you set each fixture to a different DMX address, each unit will start to “listen” to the channel number you have set, based on the quantity of DMX channels of each fixture. That means changing the settings of one channel will only affect the selected fixture.

For example, when this unit is operating in 6 channel mode, you should set the starting DMX address of the first unit to 1, the second unit to 7 (1 + 6), the third unit to 13 (1 + 6 + 6), and so on. See the chart below for more details.

CHANNEL MODE	UNIT 1 ADDRESS	UNIT 2 ADDRESS	UNIT 3 ADDRESS	UNIT 4 ADDRESS
6Ch	1	7	13	19
9Ch	1	10	19	28
10Ch	1	11	21	31
12Ch	1	13	25	37
15Ch	1	16	31	46
18CH	1	19	37	55

# DMX TRAITS

CHANNEL						DMX VALUES	FUNCTION
6Ch	9Ch	10Ch	12Ch	15Ch	16Ch		
1	1	1	1	1	1	000 - 255	<b>Red</b> , 0% to 100%
		2				000 - 255	<b>Red Fine</b>
2	2	3	2	2	2	000 - 255	<b>Green</b> , 0% to 100%
		4				000 - 255	<b>Green Fine</b>
3	3	5	3	3	3	000 - 255	<b>Blue</b> , 0% to 100%
		6				000 - 255	<b>Blue Fine</b>
4	4	7	4	4	4	000 - 255	<b>Lime</b> , 0% to 100%
		8				000 - 255	<b>Lime Fine</b>
			5	5	5	000 - 255	<b>Color Macros</b> , see <b>Color Macros Chart</b> section of this manual
			6	6	6	000 - 255	<b>Color Temperature</b> , 2700K - 7000K Linear
							<b>Color Temperature Macros</b>
						000	Off
			7	7	7	001 - 054	2700K
						055 - 109	3200K
						110 - 164	4000K
						165 - 219	5600K
						220 - 255	6500K
							<b>Shutter, Strobe</b>
						000 - 031	LEDs Off
						032 - 063	LEDs On
						064 - 095	Strobe Effect, slow to fast
	5		8	8	8	096 - 127	LEDs On
						128 - 159	Pulse Effect in Sequences
						160 - 191	LEDs On
						192 - 223	Random Strobe Effect, slow to fast
						224 - 255	LEDs On
	6		9	9	9	000 - 255	<b>Dimmer Intensity</b> , 0% to 100%
	7		10	10	10	000 - 255	<b>Dimmer Fine</b>
5	8	9	11	11	11	000 - 255	<b>Zoom Linear</b> , minimum to maximum beam angle
							<b>Zoom Presets</b>
						000 - 020	Normal (5°)
						021 - 040	Very Narrow Spot (6°)
6	9	10	12	12	12	041 - 060	Narrow (10°)
						061 - 080	Medium Flood (30°)
						081 - 100	Wide Flood (40°)
						101 - 255	Very Wide Flood (50°)

CONTINUED ON NEXT PAGE

# DMX TRAITS

CHANNEL						DMX VALUES	FUNCTION
6Ch	9Ch	10Ch	12Ch	15Ch	18Ch		
					13		<b>Auto Programs</b>
						000 - 031	Off
						032 - 063	Auto Program 1
						064 - 095	Auto Program 2
						096 - 127	Auto Program 3
						128 - 159	Auto Program 4
						160 - 191	Auto Program 5
						192 - 223	Auto Program 6
					224 - 255	Auto Program 7	
					14	000 - 255	<b>Auto Programs Speed</b> , slow to fast
					15	000 - 255	<b>Auto Programs Fade</b> , minimum to maximum fade
				13	16		<b>Dim Mode</b>
						000 - 020	Default to unit setting
						021 - 040	Standard
						041 - 060	Stage
						061 - 080	TV
						081 - 100	Architectural
						101 - 120	Theatre
						121 - 140	Stage 2
				141 - 160	Dim Speed, fast to slow (0.1s - 10s)		
				161 - 255	Default to unit setting		
				14	17		<b>Dim Curves</b>
						000 - 020	Square
						021 - 040	Linear
						041 - 060	Inv Squa
						061 - 080	S Curve
				081 - 255	No function		
				15	18		<b>Special Functions</b>
						000 - 015	Default to unit setting
						016 - 030	900 Hz
						031 - 045	1000 Hz
						046 - 060	1100 Hz
						061 - 075	1200 Hz
						076 - 090	1300 Hz
						091 - 105	1400 Hz
						106 - 120	1500 Hz
						121 - 135	2500 Hz
				136 - 150	4000 Hz		

CONTINUED ON NEXT PAGE

# DMX TRAITS

CHANNEL						DMX VALUES	FUNCTION
6Ch	9Ch	10Ch	12Ch	15Ch	18Ch		
				15	18		<b><i>Special Functions (continued)</i></b>
						151 - 165	5000 Hz
						166 - 180	10000 Hz
						181 - 195	15000 Hz
						196 - 210	20000 Hz
						211 - 225	25000 Hz
						226 - 229	Enable Zoom Mode 1 (hold 3s)
						230 - 233	Enable Zoom Mode 2 (hold 3s)
						234 - 238	Zoom Reset
						239 - 255	No function

# COLOR MACROS CHART

COLOR MACRO NUMBER	DMX VALUES	RED	GREEN	BLUE	LIME
Off	000	0	0	0	0
1	001 - 004	80	255	234	80
2	005 - 008	80	255	164	80
3	009 - 012	77	255	112	77
4	013 - 016	117	255	83	83
5	017 - 020	160	255	77	77
6	021 - 024	223	255	83	83
7	025 - 028	255	243	77	77
8	029 - 032	255	200	74	74
9	033 - 036	255	166	77	77
10	037 - 040	255	125	74	74
11	041 - 044	255	97	77	71
12	045 - 048	255	74	77	71
13	049 - 052	255	83	134	83
14	053 - 056	255	93	182	93
15	057 - 060	255	96	236	96
16	061 - 064	238	93	255	93
17	065 - 068	163	87	255	87
18	069 - 072	150	90	255	90
19	073 - 076	100	77	255	77
20	077 - 080	77	100	255	77
21	081 - 084	67	148	255	67
22	085 - 088	77	195	255	77
23	089 - 092	77	234	255	77
24	093 - 096	158	255	144	144
25	097 - 100	255	251	153	153
26	101 - 104	255	175	147	147
27	105 - 108	255	138	186	138
28	109 - 112	255	147	251	147
29	113 - 116	151	135	255	138
30	117 - 120	99	0	255	100
31	121 - 124	138	169	255	138
32	125 - 128	255	255	255	255
33	129 - 132	255	206	143	0
34	133 - 136	254	177	153	0
35	137 - 140	254	192	138	0

CONTINUED ON NEXT PAGE

# COLOR MACROS CHART

COLOR MACRO NUMBER	DMX VALUES	RED	GREEN	BLUE	LIME
36	141 - 144	254	165	98	0
37	145 - 148	254	121	0	0
38	149 - 152	176	17	0	0
39	153 - 156	96	0	11	0
40	157 - 160	234	139	171	0
41	161 - 164	224	5	97	0
42	165 - 168	175	77	173	0
43	169 - 172	119	130	199	0
44	173 - 176	147	164	212	0
45	177 - 180	88	2	163	0
46	181 - 184	0	38	86	0
47	185 - 188	0	142	208	0
48	189 - 192	52	148	209	0
49	193 - 196	1	134	204	0
50	197 - 200	0	145	212	0
51	201 - 204	0	121	192	0
52	205 - 208	0	129	184	0
53	209 - 212	0	83	115	0
54	213 - 216	0	97	166	0
55	217 - 220	1	100	167	0
56	221 - 224	0	40	86	0
57	225 - 228	209	219	182	0
58	229 - 232	42	165	85	0
59	233 - 236	0	46	35	0
60	237 - 240	8	107	222	0
61	241 - 244	255	0	0	0
62	245 - 248	0	255	0	0
63	249 - 252	0	0	255	0
64	253 - 255	0	0	0	255

# DIM SPEEDS

<b>DMX VALUES</b>	<b>DELAY TIME</b>
141	0.1 sec
142	0.2 sec
143	0.3 sec
144	0.4 sec
145	0.5 sec
146	0.6 sec
147	0.7 sec
148	0.8 sec
149	0.9 sec
150	1.0 sec
151	1.5 sec
152	2.0 sec
153	3.0 sec
154	4.0 sec
155	5.0 sec
156	6.0 sec
157	7.0 sec
158	8.0 sec
159	9.0 sec
160	10.0 sec

# DIM MODES

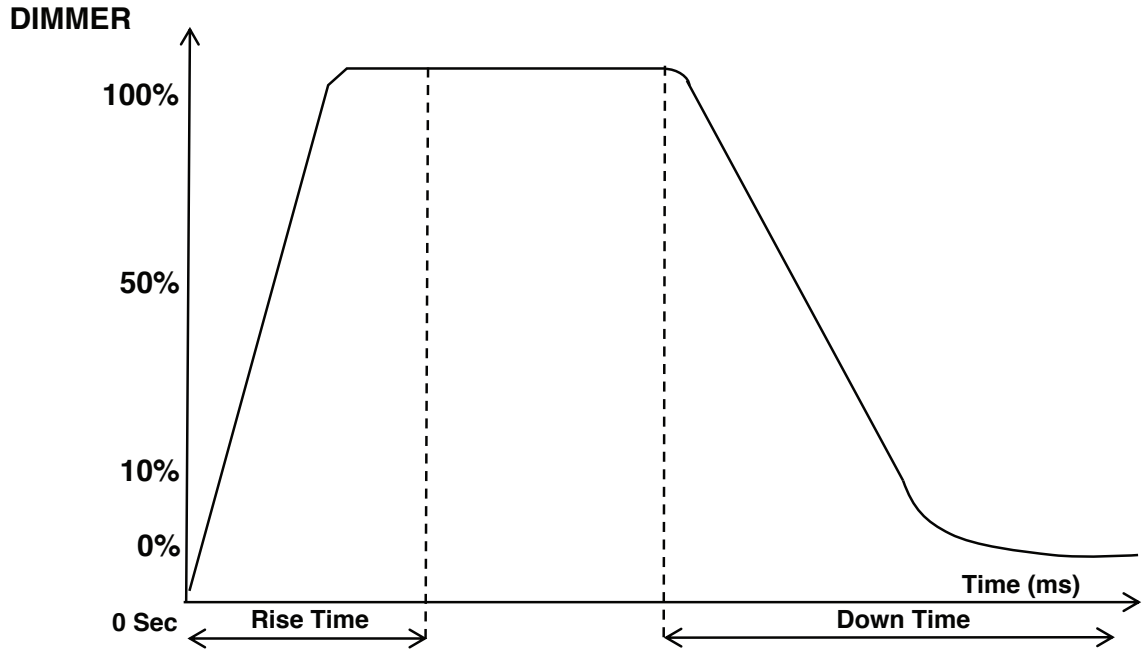

Dimming Curve Ramp Effect	0 sec Fade Time		1 sec Fade Time	
	Rise Time (ms)	Down Time (ms)	Rise Time (ms)	Down Time (ms)
Standard (default)	0	0	0	0
Stage	780	1100	1540	1660
TV	1180	1520	1860	1940
Architectural	1380	1730	2040	2120
Theatre	1580	1940	2230	2280
Stage 2	0	1100	0	1660

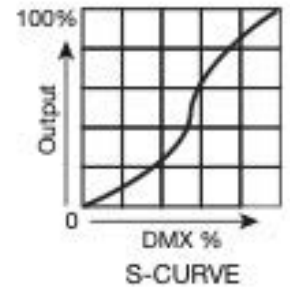
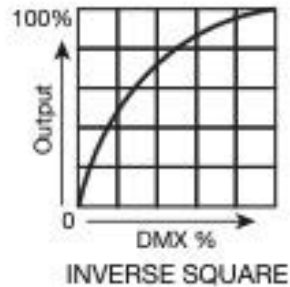
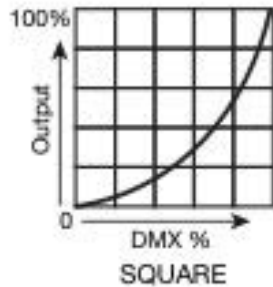
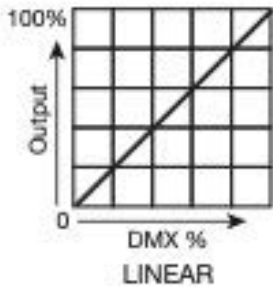

# PRIMARY-SECONDARY SET UP

This function allows you to link units together to run in a Primary-Secondary set-up, in which one unit will act as the controlling unit and the others will react to the controlling unit's built-in programs. Any unit can be configured to act as a Primary or as a Secondary, but only one unit in a given system can be programmed to act as the Primary.

## ***Primary-Secondary Connections and Settings:***

1. Daisy chain your units via the XLR connectors on the rear panels of each unit. Use standard XLR data cables to link your units together. Remember that the male XLR connector is the input and the female XLR connector is the output. The first unit in the chain (primary) will use the female XLR connector only. The last unit in the chain will use the male XLR connector only.
2. Use the display screen and control panel to navigate to Personality > PrimSec Mode. Select this sub-menu using the ENTER button, and use the UP and DOWN buttons to toggle between "Primary" and "Secondary". Press ENTER to confirm your selection.
3. Repeat Step 2 for each unit in the system. Make sure that only one unit is designated as the Primary, while all other units are designated as Secondaries.
4. The secondary units will now follow the behavior of the primary unit.

# MULTI UNIT POWER LINKING

This feature allows you to connect the fixtures to one another using the power cable input and output sockets.

**The maximum number of units that can be linked in this manner is as follows:**

- 6 units when running on 120V power.
- 14 units when running on 230V power.

***DO NOT EXCEED THIS MAXIMUM NUMBER WHEN POWER LINKING UNITS!***

All linked units must be of the same make and model type. Do not mix and match units!

# MAINTENANCE GUIDELINES



**DISCONNECT POWER BEFORE PERFORMING ANY MAINTENANCE!**

## **CLEANING**

Frequent cleaning is recommended to ensure proper function, optimized light output, and an extended life. The frequency of cleaning depends on the environment in which the fixture operates: damp, smoky, or particularly dirty environments can cause greater accumulation of dirt on the fixture's optics. Clean the external lens surface regularly with a soft cloth to avoid dirt/debris accumulation.

**NEVER** use alcohol, solvents, or ammonia-based cleaners.

## **MAINTENANCE**

Regular inspections are recommended to ensure proper function and extended life. There are no user serviceable parts inside this fixture. Please refer all other service issues to an authorized ADJ service technician. Should you need any spare parts, please order genuine parts from your local ADJ dealer.

Please refer to the following points during routine inspections:

- A. A detailed electrical check by an approved electrical engineer every three months, to make sure the circuit contacts are in good condition and prevent overheating.
- B. Be sure all screws and fasteners are securely tightened at all times. Loose screws may fall out during normal operation, resulting in damage or injury as larger parts could fall.
- C. Check for any deformations on the housing, color lenses, rigging hardware, and rigging points (ceiling, suspension, trussing). Deformations in the housing could allow for dust to enter into the fixture. Damaged rigging points or unsecured rigging could cause the fixture to fall and seriously injure a person(s).
- D. Electric power supply cables must not show any damage, material fatigue, or sediments.

**NEVER** remove the ground prong from the power cable.

## **SOFTWARE UPDATES**

Please contact ADJ service for assistance with updating your device's software.

# TORQUE SETTINGS FOR SCREWS

Following any maintenance or repair procedure that requires the opening of the fixture casing, the casing must be re-installed using a torque driver and torqued to the specified settings below. The re-assembled fixture should also be tested using an ADJ Hydro IP Tester in order to ensure that the fixture's IP rating remains valid.

**TORQUE DRIVERS (Recommended): UTICA TS-30 (Shown)**

**TORQUE DRIVER (Alternate):**

- Proto J6107A
- Wiha 28887

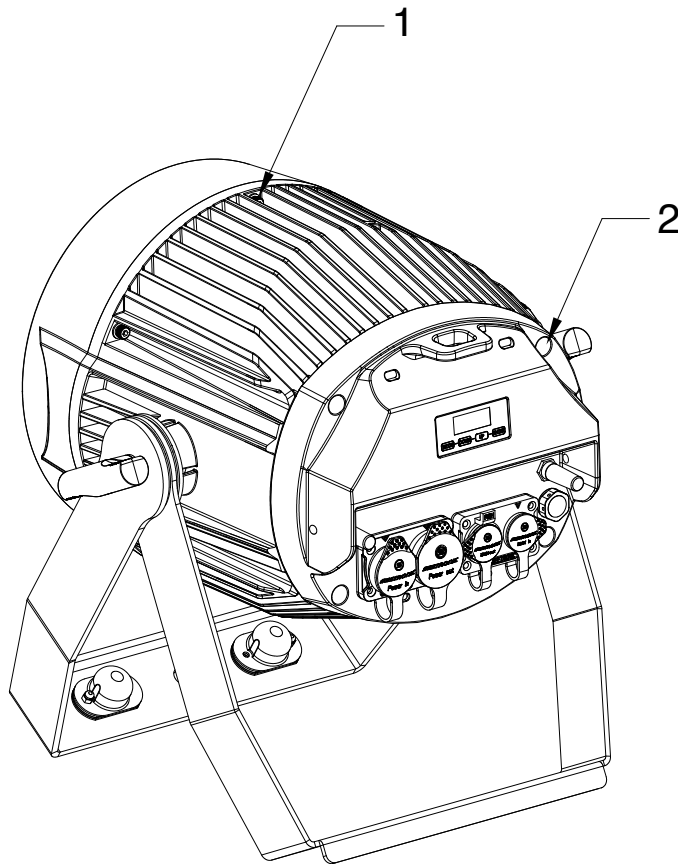

ITEM NO.	DESCRIPTION	QUANTITY	TORQUE SPEC
1	Front Cover Screw	6	8.7 ± 0.4 lb-in (10.0 ± 0.5 kg-cm)
2	Back Cover Screw	6	8.7 ± 0.4 lb-in (10.0 ± 0.5 kg-cm)

# TORQUE SETTINGS FOR SCREWS



**CAUTION! DO NOT OVER TORQUE SCREWS AS THIS CAN CAUSE LEAKAGE ISSUES! TO CONFIRM THE IP65 INTEGRITY AFTER A LAMP REPLACEMENT, TEST THE FIXTURE USING THE IP TESTER. CONTACT ADJ SERVICE FOR MORE DETAILS.**



**CAUTION! THE USE OF PROTECTIVE GLOVES AND SAFETY GOGGLES IS STRONGLY RECOMMENDED WHILE PERFORMING THE IP PRESSURE TEST! AVOID PLACING YOUR FACE, EYES, HANDS, ETC IN CLOSE PROXIMITY TO THE FIXTURE'S LENS WHILE PERFORMING THE TEST!**



<b>IP PRESSURE TESTING PARAMETERS</b>					
<b>Low Pressure Limit</b>	<b>High Pressure Limit</b>	<b>Inflation Time</b>	<b>Balance Time</b>	<b>Detection Time</b>	<b>Max Leakage</b>
3.336 psi (23 KPa)	2.901psi (20 Kpa)	30 sec	15 sec	15 sec	0.015 psi (100 Pa)

# DIMENSIONAL DRAWINGS

## FIXTURE ONLY

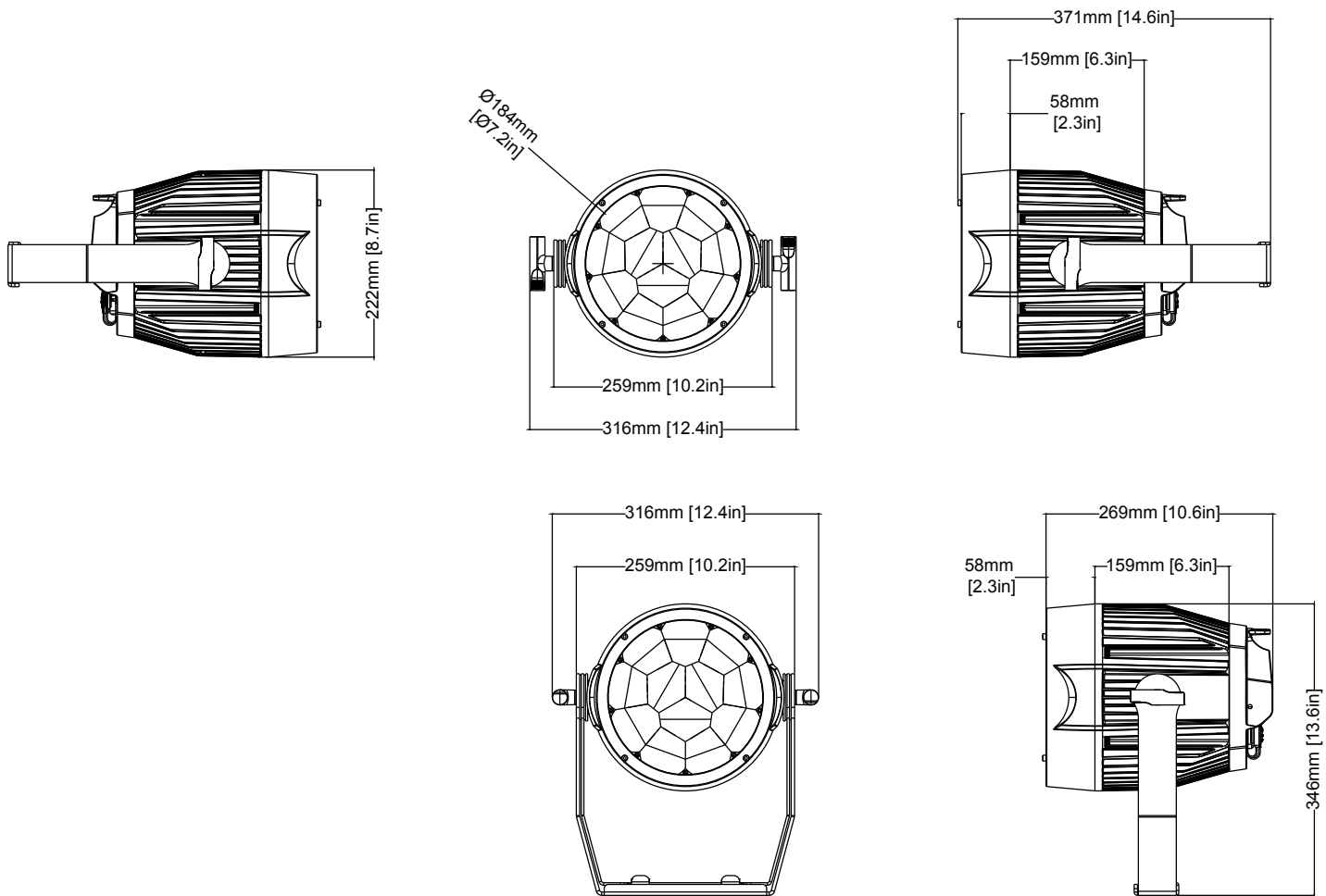

Drawings not shown to scale.

# DIMENSIONAL DRAWINGS

## GEL FRAME

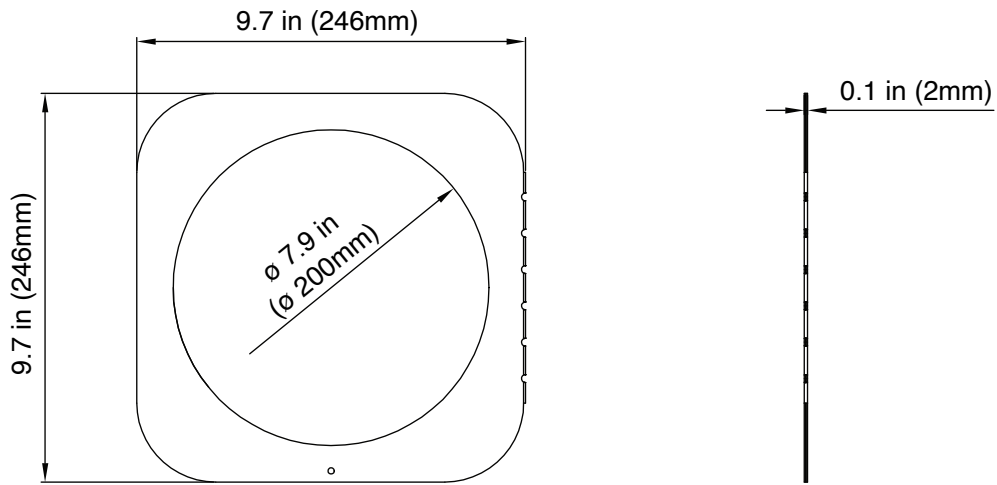

## GEL FRAME HOLDER

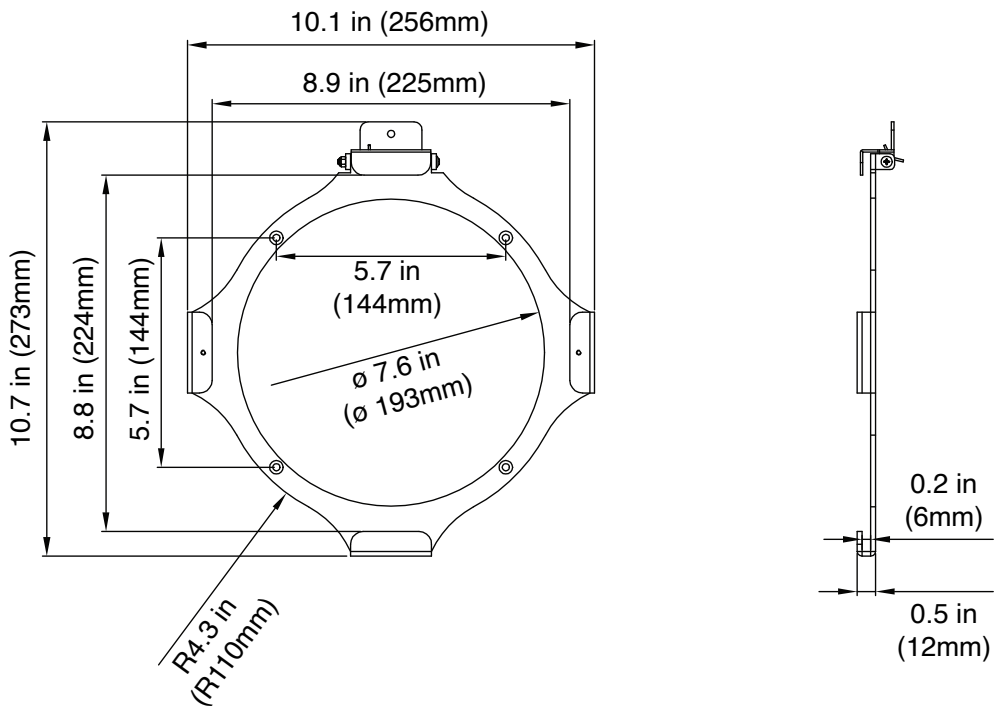

# DIMENSIONAL DRAWINGS

## BARNDOOR

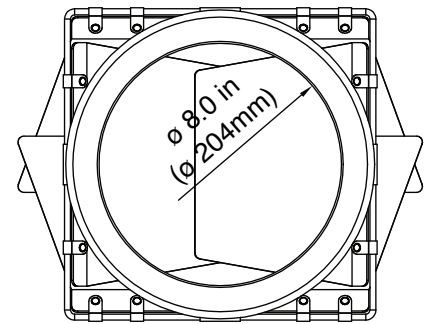
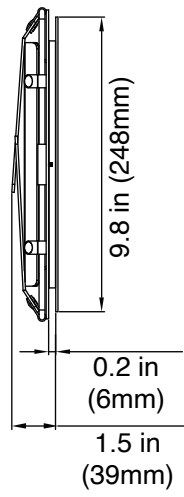
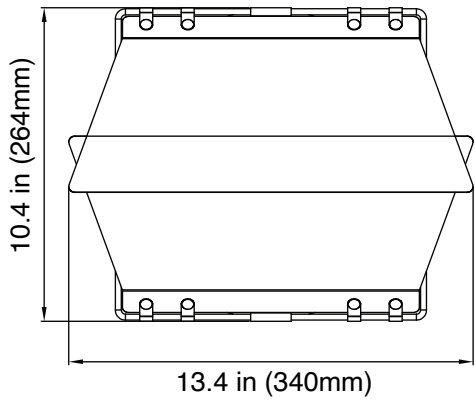

# SPECIFICATIONS

## SOURCE:

- Light Source: 12 x 20-Watt Quad RGBL LEDs (4-IN-1: Red, Green, Blue & Lime)

## PHOTOMETRIC DATA:

- Beam angle: 5° to 30°
- Field angle: 9° to 50°
- CRI: 84.4
- CRI R9: 77
- Lumens: 4400

## EFFECTS:

- Motorized Zoom (5° to 30° Beam Angle, 9° to 50° Field Angle)
- Linear Color Temperature Control (2700K to 6500K)
- Preset Color Temperatures (2700K, 3200K, 4000K, 5600K and 6500K)
- 16-Bit Fine Color Control (Red, Green, Blue & Lime)
- 64 built-in Color Macros

## CONTROL / CONNECTIONS:

- 4-button, DMX digital display on rear panel
- Operational modes: Static Color Mode, RGBL Dimmer Mode, Program Mode and DMX Controlled
- Wireless DMX on-board
- Supports RDM (Remote Device Management)
- With Wired Digital Communication Network
- 6 selectable Dimming Modes (Standard, Stage, TV, Architectural, Theatre & Stage 2)
- 4 selectable Dim Curves (Linear, Square Inv. Squa, S-Curve)
- Adjustable Refresh Rate (14 presets from 900 – 25,000Hz)
- Flicker Free operation (No flickering on camera)
- LED pulse and strobe effect
- Electronic Dimming: 0 - 100%
- 6 DMX Modes: 6, 9, 10, 12, 15 & 18-channel
- Quiet fan mode

## CONSTRUCTION:

- IP65 Rated: Ingress Protection against liquid, snow, dust and sand
- All aluminum construction
- Marine Grade Coating: C3
- IP Rated rubber covers protect In/Out Locking Power connectors and IP rated 5-pin sockets
- Locking, outdoor In/Out Power connectors
- Data linkable via 5-pin XLR DMX connections
- Scissor Yoke & safety eye

## ELECTRICAL / THERMAL:

- Multi-voltage operation: AC 100-240V, 47/63Hz
- Daisy chain: 6 @ 120V, 12 @ 220V
- Max power: 227W
- Ambient Operating Temperature Range: 14°F ~ 113°F (-10°C ~ 45°C)

## DIMENSIONS / WEIGHT:

- Dimensions (LxWxH): 14.6" x 12.4" x 13.6" (371mm x 316mm x 346mm)
- Weight: 16.6 lbs. / 7.5 kg.

## APPROVALS / RATINGS:

- cETLus
- CE
- FCC
- UKCA
- IP65



IP65

*Please Note: Specifications and improvements in the design of this unit and this manual are subject to change without any prior written notice.*

## OPTIONAL ACCESSORIES

ORDER CODE (US)	ORDER CODE (EU)	DESCRIPTION
ELP18L100	1226100403	100° frost filter
ELP18L60	1226100402	60° frost filter
ELP18L30X60	1226100405	30x60° frost filter
ELP18L1X40	1226100404	1x40° frost filter
ELP18L20	1226100401	20° frost filter
Z-8050000053	1226100419	107mm Omega Bracket
ELP18IPBDA	1226100416	Barn Door / Gel Frame Kit

## ERROR CODES

CODE	DESCRIPTION
ZOOM ERROR	Zoom Motor Error
TEMP ERROR	Temperature Error

## FCC STATEMENT

This device complies with Part 15 of the FCC Rules. Operation is subject to the following two conditions: (1) this device may not cause harmful interference, and (2) this device must accept any interference received, including interference that may cause undesired operation.

### FCC RADIO FREQUENCY INTERFERENCE WARNINGS & INSTRUCTIONS

This product has been tested and found to comply with the limits as per Part 15 of the FCC Rules. These limits are designed to provide reasonable protection against harmful interference in a residential installation. This device uses and can radiate radio frequency energy and, if not installed and used in accordance with the included instructions, may cause harmful interference to radio communications. However, there is no guarantee that interference will not occur in a particular installation. If this device does cause harmful interference to radio or television reception, which can be determined by turning the device off and on, the user is encouraged to try to correct the interference by one or more of the following methods:

- Reorient or relocate the device.
- Increase the separation between the device and the receiver.
- Connect the device and the radio receiver to electrical outlets on different electrical circuits.
- Consult the dealer or an experienced radio/TV technician for help.



*This page intentionally left blank.*

